

MISC. ALFA ROMEO SPIDER WINDSHIELD & DOOR TRIM, 1966-94

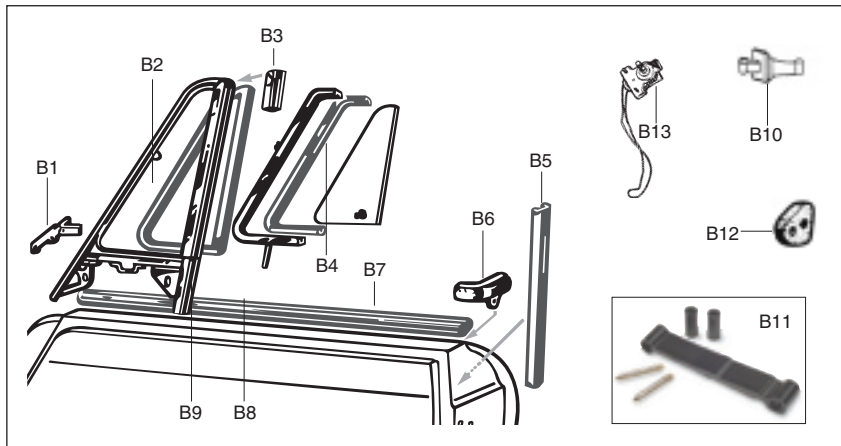
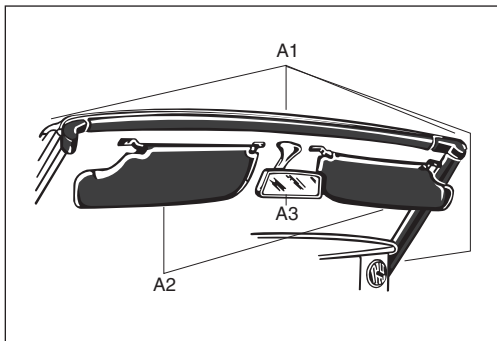

For convertible top hardware and moldings, see page 5.

WINDSHIELD TRIM

- A1** Plastic trim kit, all 5 pcs. around interior of windshield frame, 1971-94 (black)
- A2** Sun visor, 1967-69 (driver side has mirror)
- A2** Sun visor, 1971-94* (pin not included; #30275 has mirror)
- Pin for visor 30276/30275 (req. 2 per visor)
- A3** Inside rear view mirror, glass and housing, 1971-94 (not lighted)
- A3** Inside rear view mirror and glass, 1971-94 (not lighted)

* As orig. on 1971-1985 all, 1986-90 Graduate.
Will work for Veloce, but appearance not as original.

Item No.	Item No.	Price
Driver	Pass.	
30294	—	\$209.50
30305	30304	67.50
30276	30275	49.50
4779	4779	8.45
24532	—	82.50
24553	—	29.95

DOOR TRIM

- B1** Rubber door drip deflector, front (also in kit #43595)*
- Retainer for #43622/43621 (need 2 per side)
- B2** Vent window gasket, 1971-94
- B3** Channel molding cap (also in kit #43595)*
- B4** Vent window glass weatherstrip (need 4 per side)
- B5** Window channel molding, rear
- B6** Rubber door drip deflector, rear (need 1 per side) (in kit #43595)*
- Retainer for #43624/43623 (need 1 per side)
- B7** Outer window scraper set, for entire car
- B8** Inner window scraper (need 1 per side)
- B9** Window channel molding, front (need 1 per side)
- B10** Door check assembly (limits opening)
- B11** Door check repair kit, incl. check strap and rollers
- Main Rubber Door Molding (Door Gasket):
- 1967-69 (need 1 per side)
- 1971-94, w/ velour inside portion (need 1 per side)
- 1971-94, as above but smooth rubber (need 1 per side)
- Door molding rubber end plug (need 1 per side) (in kit #43595)*
- Side window (door) glass, 1971-94 (bronze tint) (L or R)
- B12** Door lug (buffer)
- B13** Window regulator, 1967-69
- B13** Window regulator, 1971-78
- B13** Window regulator, 1979-89 (not power)

* Available in an 8-piece door gasket kit for 1966-94 Spiders, #43595, \$72.95

43622	43621	\$ 9.25
25406	25406	1.90
43616	43617	53.95
43567	43608	7.95
43520	43520	7.50
82742	82742	14.25
43624	43623	11.25
25406	25406	1.90
43551	—	24.95
43591	43591	10.50
43612	43612	10.50
03526	03526	82.50
03527	03527	44.75
82716	82716	29.95
43671	43671	48.95
82721	82721	31.50
82715	82715	5.50
43809	43809	179.50
03568	03623	12.75
93516	93517	46.95
93507	93508	47.95
93543	93544	78.95

MISC. INTERIOR TRIM, 1966-94



Item No.	Item No.	Price
Driver	Pass.	
22258	—	\$35.95
11816	11816	41.50
93564	—	45.95
93555	—	2.35
25029	—	2.10
25069	—	2.65
25031	—	2.90
43689	43691	94.25
93417	93403	51.95
23672	—	41.95
03626	—	38.95
17627	—	29.50



KEEP YOUR WINDOWS WORKING

Older Alfas, like many Italian cars of the era, tended to have slow-moving power windows—even when new. Time, use and built-up grit and dirt can combine to make the problem worse.

If the windows are slower than normal or not working at all, first clean the connections at the motors and switches. We suggest using Würth Contact Cleaner (#42821, pg. 46).

Next, use a high quality silicone spray (available at most major home improvement stores) and liberally lubricate the window tracks.

Finally, use silicone spray on the cable and also on the drum that winds the cable. In addition to lubricating the cables, the silicone will protect them from corrosion.

If you repeat this process at the beginning of each season, you may avoid a regulator or motor failure.