

ALFA ROMEO GIULIETTA & GIULIA SPIDER, 1956-65

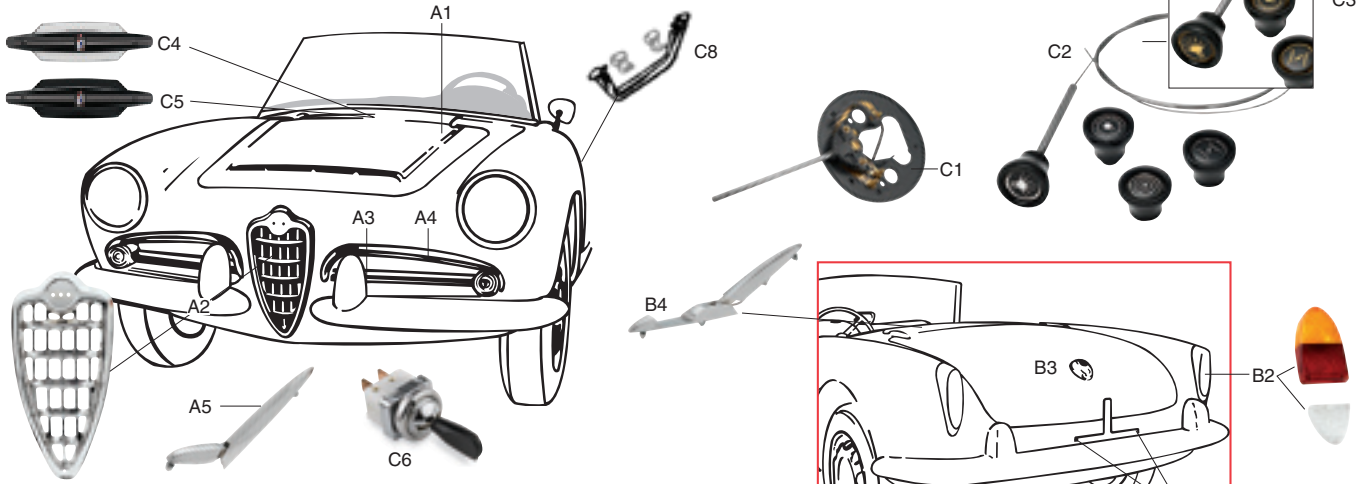

FRONT END

	Item No.	Item No.	Price
	Driver	Pass.	
A1 Hood scoop trim, Giulia 101	34234	—	\$234.00
A2 Grille (center), all 750 & 101 (emblem not included – see page 77)	34233	—	339.00
A3 Grille insert, (center bar) all 750 & 101	34232	34231	95.50
A4 Grille “eyebrow,” all 750 & 101	34229	34228	289.00
A5 Hood hinge set (L & R), all 750 & 101	34238	—	339.00
– Underhood pad, finished, correct pattern but padding is fiberglass, all 750 & 101	34244	—	99.50
– Underhood pad, correct material but not finished; 100 x 200cm, all 750 & 101	34237	—	119.00
– Rubber hood bumper, (set of 2) 1956-64	56753	—	13.95
– Wiper blades (set of 2), Giulia 101 w/bayonet arm	56751	—	25.95
– w/hook-style arm	56752	—	25.95

REAR

B1 Carello license plate lamp, need 2, no bulb (see page 76 for bulbs)	34408	34408	119.50
B2 Tail light lens, amber/red with white backup lens, L or R, Giulia 101 only	34243	34243	97.50
B3 Trunk handle	34226	—	349.00
B4 Trunk hinge set (L & R), Giulia only	34239	—	315.00
– Trunk rubber molding, fits on body not trunk lid, all 750 & 101	34242	—	82.50

MISCELLANEOUS

	Item No.	Item No.	Price
	Driver	Pass.	
C1 Column switch, all 750 & 101	34216	—	\$249.00
Dash switch/knob set, 4, w/ choke cable:			
C2 Black/ Silver for 750/101 Giulietta	34218	—	219.00
C3 Black/ Gold for 101 Giulia	34217	—	219.00
C4 Radio blanking plate, Giulietta, 1956-62	02021	—	137.50
C5 Radio blanking plate, Giulia, 1962-65	02022	—	119.00
– Chrome dash gauge trim ring, need 3, all 750 & 101	56764	—	46.50
C6 Under dash toggle switches, Giulia Spider, 1962-65	34428	—	32.25
C7 Foot switch for headlight dimmer	56774	—	79.50
C8 Door gasket, front section, L or R, fits Giulietta 101 & Giulia 101 only	34236	34236	39.95
– Door gasket, rear section, L or R, fits Giulietta 101 & Giulia 101 only	34235	34235	85.95
C9 Hood & trunk hinge rubber gasket set (all 4 pieces), all 750 & 101	34241	—	45.50
– Top latch	56763	—	137.50
– Battery cover, top (rubber)	56775	—	76.50
– Battery cover, bottom (rubber)	56776	—	54.95



Bonneville 2009 225 + 230 = 2 New Records!

(WENDOVER, UT) “Bonnie,” the IAP-backed ‘91 Alfa Spider owned by Richard Kreines, set two different class records during the 2009 edition of Bonneville Speedweek. After a disappointing 2008 effort, tuning expert Jim Steck and car builder Mike Besic spent the year working on engine cooling and aerodynamics. Obviously, the tweaks worked.

The team regained the G/BFMS (Blown Fuel Modified Sports) record when driver Bill Lightfoot drove the turbocharged 4-cylinder Alfa to a 2-way average speed of 225.839 mph. That snatched the record back from a 221-mph Nissan and got Lightfoot into Bonneville’s exclusive 200 MPH Club.

With that goal achieved, the Autocomponenti/Besic Motorsports team switched over to G/BGMS (blown gas) in an attempt to up Steck’s 217.152 class record set in 2006. Clutch problems threatened to derail the effort, but with a new assembly installed, Steck ran a 230.368 on Thursday; then further obliterated the old mark with a 232.869 Friday morning, setting the new record at 230.352 and closing out a truly remarkable week of racing.

Congratulations to Richard, Jim, Mike, Bill and the crew on a terrific effort!