

ALFA ROMEO SPIDER, GTV

Imported from Italy or Germany.

GIULIETTA & GIULIA, 1955-65

Item No.	Price Each
Front swaybar center bushing	56777 \$ 26.95
Trailing arm bushing (need 4)	56778 39.90
Trunion bushing (need 2)	56779 69.90
Upper ball joint	56765 209.00
Lower ball joint	56766 209.00
Tie rod end set (need 3)	107172 31.50

SPIDER & GTV, 1966-94

Front Suspension

Tie rod end set (set replaces left or right side only)	107172	\$31.50
Center link end set (incl. both ends of center link)	109596	31.50
Center link sleeve	33512	49.50
Upper ball joint with arm and bushings, driver side	19400*	74.75
Upper ball joint with arm and bushings, pass. side	19300*	74.75
Inner ball joint at fender	21035	28.45
Upper spring seat (metal), L or R	21512	18.50
Front spring cushion ring, fits upper or lower, L or R	21511	8.95
Lower front spring steel pan (spring seat), driver side	21532	69.50
Lower front spring steel pan (spring seat), pass. side	21533	69.50
Lower ball joint	21019	31.50
Front suspension bump stop (round)	34008	25.95
Control arm bump stop, upper	34065	12.50
Steering idler bushing kit	33505	35.50
Sway bar end link, left, Spider 1986-on (w/o bushngs)	33514	54.50
Sway bar end link, right, Spider 1986-on (w/o bush.)	33513	54.50

Front Suspension Bushings

Upper control arm caster bushing, 1978-on	61015	\$ 7.35
Upper control arm caster bushing, 1966-78	91031*	5.75
Upper control arm inner bushing	91017	24.95
Lower A-arm bushing, need 2 per side	91018	32.95
Cup	33558	8.95
Cap	33561	8.50
Sway bar center bushing, 1750, 2000, 1969-94	91019	6.50
Sway bar end link bushing, 1750, 2000 thru 1974, 30mm	91020	5.95
Sway bar end link bushing, 1975-85, 33mm	91007	4.95
End link w/ new bushings installed, L or R, 1975-85	33515	59.95
Sway bar end link bushing 1600, upper (1 per side), 26mm	61021	5.95
Sway bar end link bushing 1600, lower (2 per side)	91022	4.75

Rear Suspension

Sway bar center bushing, 1750-2000, all	91023	\$ 5.95
Sway bar end bushing, upper, 1750-2000, all	61021	5.95
Sway bar end bushing, lower, 1750-2000, all	61021	5.95
Front, trailing arm bushing, 1600	91026	7.95
Front, trailing arm bushing, 1750-2000	91027	17.50
Rear, trailing arm bushing, all	91028	13.50
Trunion bushing (2 per car)	91029	3.20
Trunion to body bushing (2 per car)	91034	34.95
Trunion washer, poly	33562	8.95
Rear spring rubber cushion ring, fits left or right side	335012	16.95
Rear spring metal cup, fits left or right side	335013	25.50

*Need caster washer, #91016, \$7.95

Spider and GTV

FRONT

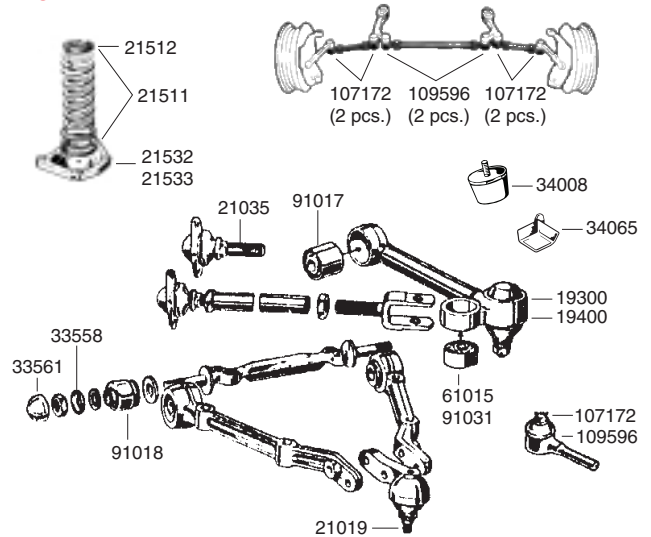

SWAY BAR

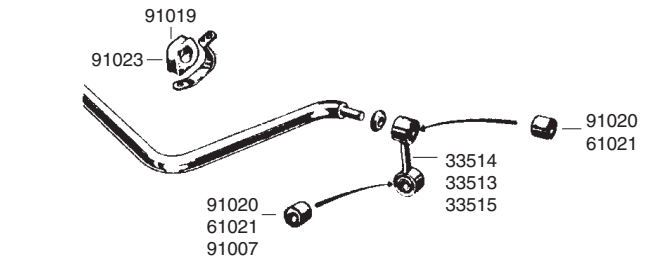

REAR

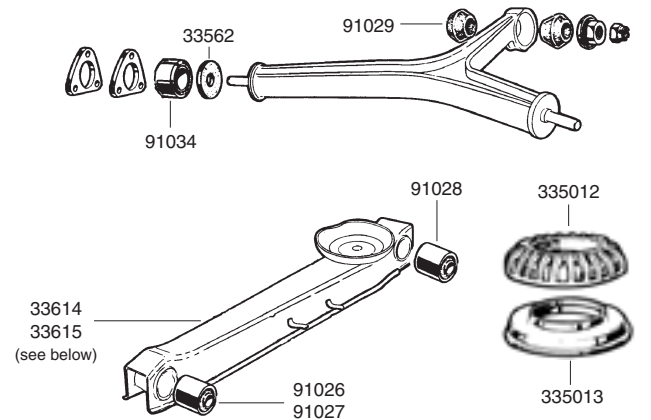

For rear axle bump stops and limiting straps, see page 58.

ADJUSTABLE UPPER CONTROL ARMS

FOR ALFA ROMEO SPIDER, 1966-94 AND GTV, 1966-74

- Allows the proper amount of negative camber to reduce understeer for better handling and even tire wear. Critical for accident-damaged cars where the frame or suspension is bent out of alignment.
- Racers need adjustable camber for precise handling, but you can use them on your street-driven Alfa Romeo.

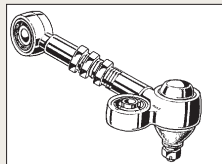

Driver side adjustable arm, #61018, \$112.50 ea.
Passenger side adjustable arm, #61019, \$112.50 ea.

Note: Need caster washer (2 per side), #91016, \$7.95

REPLACEMENT REAR TRAILING ARM

FOR ALFA SPIDER, GTV 1966-1994
AVAILABLE WITH OR WITHOUT BUSHINGS

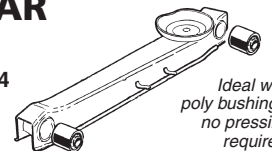

Ideal with poly bushings; no pressing required.

New trailing arm bushings make a huge difference in handling, but replacing them without damaging the trailing arm is very hard to do. To save heartache, order our reconditioned trailing arm. The \$80 core charge will be returned when we receive your old trailing arm (it's best if you do not attempt to remove the bushings first; we can't accept damaged arms). Fits L or R.

Rear trailing arm with stock bushings installed, #33614, \$109.00 ea.
Rear trailing arm without bushings (for use with poly bushings, page 51), #33615, \$89.00 each