

## MISC. ALFA ROMEO SPIDER WINDSHIELD & DOOR TRIM, 1966-94

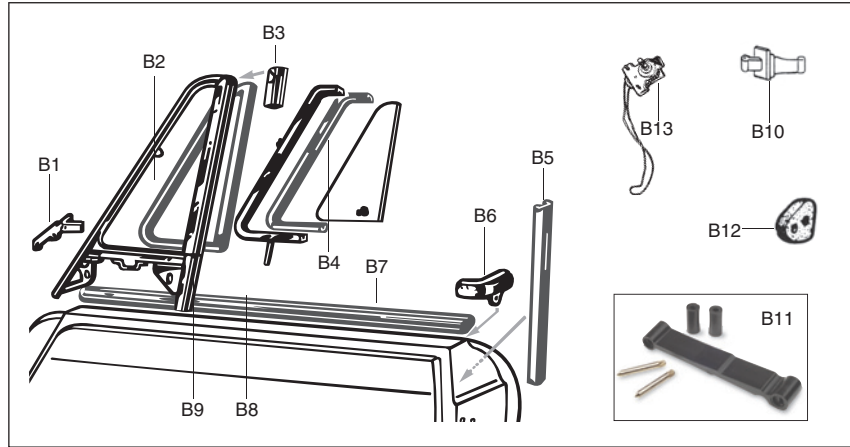
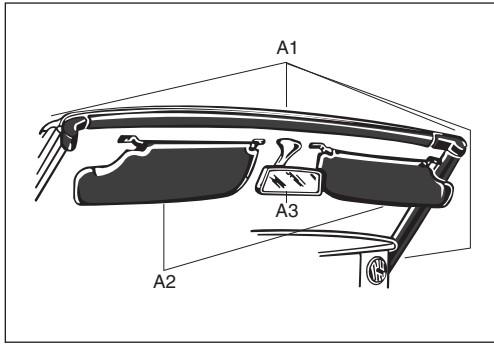

For convertible top hardware and moldings, see page 5.

### WINDSHIELD TRIM

Item No.	Driver	Item No. Pass.	Price
A1	Plastic trim kit, all 5 pcs. around interior of windshield frame, 1971-94 (black)	30294	—
A2	Sun visor, 1967-69 (driver side has mirror)	30305	30304
A2	Sun visor, 1971-94* (pin not included; #30275 has mirror)	30276	30275
-	Pin for visor 30276/30275 (req. 2 per visor)	4779	4779
A3	Inside rear view mirror, glass and housing, 1971-94 (not lighted)	24532	—
A3	Inside rear view mirror and glass, 1971-94 (not lighted)	24553	—

\* As orig. on 1971-1985 all, 1986-90 Graduate.  
Will work for Veloce, but appearance not as original.

### DOOR TRIM

B1	Rubber door drip deflector, front (also in kit #43595)*	43622	43621	\$ 9.25
-	Retainer for #43622/43621 (need 2 per side)	25406	25406	1.90
B2	Vent window gasket, 1971-94	43616	43617	53.95
B3	Channel molding cap (also in kit #43595)*	43567	43608	8.25
B4	Vent window glass weatherstrip (need 4 per side)	43520	43520	7.50
B5	Window channel molding, rear	82742	82742	14.25
B6	Rubber door drip deflector, rear (need 1 per side) (in kit #43595)*	43624	43623	11.25
-	Retainer for #43624/43623 (need 1 per side)	25406	25406	1.90
B7	Outer window scraper set, for entire car	43551	—	24.95
B8	Inner window scraper (need 1 per side)	43591	43591	10.50
B9	Window channel molding, front (need 1 per side)	43612	43612	10.50
B10	Door check assembly (limits opening)	03526	03526	82.50
B11	Door check repair kit, incl. check strap and rollers	03527	03527	44.75
-	Main Rubber Door Molding (Door Gasket):			
-	1967-69 (need 1 per side)	82716	82716	29.95
-	1971-94, w/ velour inside portion (need 1 per side)	43671	43671	48.95
-	1971-94, as above but smooth rubber (need 1 per side)	82721	82721	31.50
-	Door molding rubber end plug (need 1 per side) (in kit #43595)*	82715	82715	5.50
-	Side window (door) glass, 1971-94 (bronze tint) (L or R)	43809	43809	179.50
B12	Door lug (buffer)	03568	03623	12.75
B13	Window regulator, 1967-69	93516	93517	46.95
B13	Window regulator, 1971-78	93507	93508	47.95
B13	Window regulator, 1979-89 (not power)	93543	93544	78.95

\* Available in an 8-piece door gasket kit for 1966-94 Spiders, #43595, \$72.95

### MISC. INTERIOR TRIM, 1966-94



Item No.	Driver	Item No. Pass.	Price
D1	Heat/vent diffuser, 68mm, 1986-94 style, will also fit 1971-85	22258	—
D2	Defroster vent (dash top), approx. 80mm, 1986-94	11816	11816
D3	Gas Pedal, 1971-89	93564	—
D4	Pedal pad, clutch or brake	93555	—
D5	Door panel clip, nylon button type	25029	—
D6	Door panel clip, male	25069	—
D7	Door panel clip plug (female for #25069)	25031	—
D8	Chrome top cap for rear of door gskt., 1966-69	43689	43691
D9	Chrome top cap for rear of door gskt., 1970-on	93417	93403
D10	Shift Knob, 1969, original 5-speed type, 15mm shaft	23672	—
-	Ash tray, 1986-94	03626	—
D11	Chromed plastic gauge bezel, angled, fits 1971-85 temp, fuel or oil pressure gauge (not black like 1982-85) (need 3)	17627	—



### KEEP YOUR WINDOWS WORKING

Older Alfas, like many Italian cars of the era, tended to have slow-moving power windows—even when new. Time, use and built-up grit and dirt can combine to make the problem worse.

If the windows are slower than normal or not working at all, first clean the connections at the motors and switches. We suggest using Würth Contact Cleaner (#42821, pg. 38).

Next, use a high quality silicone spray (available at most major home improvement stores) and liberally lubricate the window tracks.

Finally, use silicone spray on the cable and also on the drum that winds the cable. In addition to lubricating the cables, the silicone will protect them from corrosion.

If you repeat this process at the beginning of each season, you may avoid a regulator or motor failure.