

FLEXIBLE JOINT DISCS FOR DRIVE SHAFTS

If the rubber doughnut is split, torn or dry-rotted, it should be replaced. Our flex joints will reduce vibration. Original Italian.

ALFA ROMEO	Item No.	Price
2600, 1600, 1750, 2000, (not automatic), 1965-94	67974	\$ 32.75
Alfetta, 1975-76: Center	630202	139.95
Alfetta, 1976-80: Front Center	30110	63.95
Center	930205	49.50
Rear 1976-77	930205	49.50
Rear 1978-80	044020	76.25
GTV6, 1981-86: Front Center	15301*	76.95
Center	15300	199.50
Rear	15023**	98.50
Milano, all: Front	15301*	76.95
Rear	15023**	98.50
Center:		
2.5, 1987 to engine no. 205227	15300§	199.50
2.5, 1987 from engine no. 205228	930205§	49.50
2.5, 1988 all and 1989 automatic	930205§	49.50
2.5, 1989 5-speed	15300 §	199.50
3.0, all	15300 §	199.50

FIAT, PININFARINA	Item No.	Price
124 & 131, all, Pinin., 1968-85	79740	\$23.95

Notes: * Seal for #15301 is #29754, **\$12.95**;
Split bearing is #11123, **\$62.50**
** Grommet for #15023 is #11124, **\$8.95**
§ 15300 is 1" thick; 930205 is 1 1/8" thick.
Seal for #15300 & 930205 is #13771, **\$6.50**

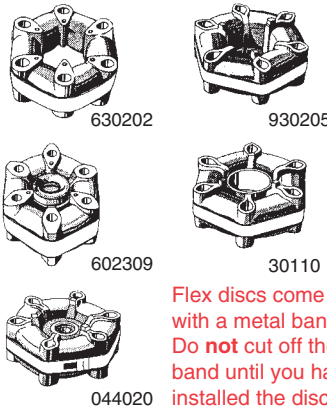

Flex discs come with a metal band. Do not cut off the band until you have installed the disc.

ALFETTA DISCS

Identifying the correct flex disc on Alfas can be difficult. They were changed in the '76 model year. So those, you must inspect to determine whether they are early or late. See drawings above. There were several recalls to replace flex discs, so many Alfas had them replaced. Metal bands shown on discs are removed after installation. They will not appear on your car.

U-JOINTS FOR ALFA ROMEO & FIAT

Worn universal joints can increase vibration in your drivetrain. Our U-joints are perfect replacements.



ALFA ROMEO
1300, 1600, all 1958-68, #36502, **\$39.50**
1750, 2000 Spider 1969-94 and Berlina, GTV, 1969-74, #9370, **\$21.75**

FIAT, PININFARINA
124 Coupe, Spider, Pininfarina, 131, 1968-85, #9400, **\$18.95**

DRIVE SHAFTS

Before removing a drive shaft, be sure to mark the flanges for reassembly.

NEW DRIVESHAFTS FOR ALFA ROMEO



The easiest way to replace both U-joints—and ensure a perfectly-balanced driveshaft. New (not remanufactured) rear drive shaft sections, complete with U-joints & yokes.

GTV, 1965-71 (8mm holes), #13776, **\$389.00**
GTV, 1972-74 (9mm holes), #13778, **\$390.00**
Spider, 1966-71 (8mm holes), #13777, **\$399.00**
Spider, 1972-94 (9mm holes), #13779, **\$408.00**
Flange bolts for #13779 #20218, **\$6.80**

DRIVE SHAFT SUPPORTS FOR ALFA ROMEO AND FIAT

	Support	Bearing	Slinger	Clip				
	Item No.	Price	Item No.	Price				
Alfa Romeo Giulia 1600 GT, Duetto, Super 1965-68	7334	\$ 8.95	62062	\$16.75	4815*	\$16.95	4115	\$4.95
All 1750, 2000, 1969-74; Spider, 1975-on	7212	35.55	62062	16.75	—	—	—	—
All Giulietta, Giulia, GTV & Spider 1956-94**, Centralizing bushing (in front of driveshaft)	—	—	29757	59.95	—	—	—	—
Alfetta GT, Sedan, 1978-80 (One bolt hole offset, 140mm apart)	12702	24.95	1503	13.25	—	—	—	—
GTV6, Milano, all	15127	27.50	1208	15.95	13751*	19.95	—	—
FIAT, PININFARINA 124, 2000 Spider, 131, Brava 1969-85	2970	\$23.95	4232	\$28.50	—	—	13757	\$2.85

Notes: *Need two slingers. Rubber only. **Rubber bump at flex joint end of drive shaft (drive shaft rubber), #29755, **\$10.25**

DRIVE SHAFT SUPPORT

We recommend new bearings with any drive shaft support (& vice-versa). Bearings are often damaged during removal.

FIAT SPIDER DIFFERENTIALS

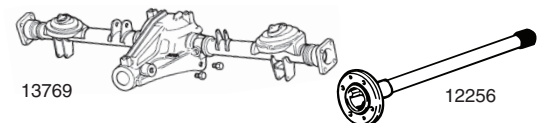

Why take chances with a junkyard differential? Our remanufactured unit comes complete with ring & pinion, axle housing, rear cover and axle seals. Just install your original axle shafts and you're ready to roll. Fits 5-speed Fiat and Pininfarina Spiders, 1978-85. Truck freight.

Early (CS) cars w/ 24.8mm axle splines, #13769, **\$1,790**
For use with #13769, axle shaft, #12256, **\$179.50**
Late (DS) cars w/ 26.2mm axle splines, #13774, **\$1,890**

AXLE LIMIT STRAPS FOR ALFA ROMEO

Fits 1972-on Alfa Spider, GTV, Berlina (not Alfetta), Milano or 164) rear suspension. Need two each.



	Item No.	Price Ea.
Inner Strap	33502	\$12.75
Outer Strap	33503	12.95
Special mounting screw (4 per car)	25066	4.95

AXLE BUMP STOP FOR ALFA, FIAT

1962-94 Alfa 1600, 1750 & 2000 (not Alfetta), (2 req.) #44202, **\$18.50 each**



1968-84 Fiat 124 Spider, (2 req.) #34045, **\$28.50 each**

For Alfa screws, see left.

REAR DIFFERENTIAL GASKETS FOR ALFA ROMEO, FIAT

1956-94 Alfa Spider, GTV, Sprint, Berlina (not Alfetta), #19006, **\$6.95**
1978-84 Fiat 124 Spider, #4430509, **\$4.95**